

# ATLAS Teamwork: ATLAS Teamwork:

## AR 35/35 Super



Operation weight 2500 kg / 2875 kg  
 Power 24.6 kW (33.5 HP) / 29.4 kW (40 HP)  
 Shovel capacity 0.34 m<sup>3</sup> / 0.40 m<sup>3</sup>

## AR 40



Operation weight 3300 kg  
 Power 29.4 kW (40 HP)  
 Shovel capacity 0.50 m<sup>3</sup>

## AR 50



Operation weight 3950 kg  
 Power 42 kW (57 HP)  
 Shovel capacity 0.70 m<sup>3</sup>

## AR 60



Operation weight 4650 kg  
 Power 47.5 kW (65 HP)  
 Shovel capacity 0.85 m<sup>3</sup>

## AR 65 Super



Operation weight 4800 kg  
 Power 51.3 kW (70 HP)  
 Shovel capacity 0.80 - 1.00 m<sup>3</sup>

## AR 75



Operation weight 5600 kg  
 Power 55 kW (75 HP)  
 Shovel capacity 1.00 m<sup>3</sup>

## AR 75 S



Operation weight 6000 kg  
 Power 55 kW (75 HP)  
 Shovel capacity 0.80 m<sup>3</sup>

## AR 80



Operation weight 5750 kg  
 Power 59.3 kW (81 HP)  
 Shovel capacity 1.00 m<sup>3</sup>

## AR 85



Operation weight 6700 kg  
 Power 71.2 kW (97 HP)  
 Shovel capacity 1.30 m<sup>3</sup>

## AR 95/95 Super



Operation weight 7900 kg / 8100 kg  
 Power 74.9 kW (102 HP) / 92 kW (125 HP)  
 Shovel capacity 1.40 - 1.60 m<sup>3</sup>

Technical data without engagement.  
 Subject to change without notice.

**ATLAS**  
 WEYHAUSEN

ATLAS WEYHAUSEN GmbH  
 Maschinenfabrik  
 Visbeker Straße 35  
 D-27793 Wildeshausen  
 Telephone +49 (0)44 31/981-0  
 Fax +49 (0)44 31/981-225  
 www.radlader.com

01/2010



- Landscaping, construction trade, recycling, material handling, civil engineering works and road construction
- Operating weight: 4800 kg
- Power: 51.3 kW

**ATLAS**  
 WEYHAUSEN

## TECHNICAL DATA SHEET AR 65 Super

### Engine

Make: Deutz Diesel engine TD 2011 L04  
 Type: oil/air cooled  
 Power<sup>\*\*\*</sup>: 51.3 kW (70 hp)  
 at 2200 min<sup>-1</sup>  
 Max. torque: 240 Nm at 1600 min<sup>-1</sup>  
 Stroke: 3243 cm<sup>3</sup>  
 Cylinders: 4 in line  
 Electrical System: Operating voltage 12V  
 Battery 12V/88 Ah  
 Alternator 14V/80 A  
 Starter 12V/2,3 kW

### Drive

- Output regulated hydrostatic drive with pressure cut off and closed circuit acting on all 4 wheels
- Speed with standard tires:  
 Operating speed range 0-6,5 km/h  
 Road speed range 0-20 km/h  
 Optional high speed 0-40 km/h
- 1st and 2nd hydraulic gear can be engaged under load, forward/backward travel also
- Activation forward/backward travel and speed ranges via ATLAS joystick
- Drive operated by accelerator and separate inching pedal for best distribution of the hydraulic power for thrust and lifting forces

### Axles

Rigid axles with planetary reduction gears in wheel hubs, electrically connected 100% - differential lock in front and rear axle.

### Brakes

**Standard brake:** Multi-disc brake in oil bath acting on all 4 wheels. Supplementary brake functions via inching pedal and hydrostatic drive acting on all 4 wheels.

**Parking brake:** Parking brake as spring-loaded brake acting on all 4 wheels. In case of standstill of engine the spring-loaded brake is automatically re-activated.

### Steering

- Fully hydraulic center pivot steering
- Front and back wheels follow the same track
- Steering angle 40° to each side, ± 12° angular movement in rear of vehicle
- Operating pressure of steering hydraulics 175 bar
- Emergency steering function

### Hydraulic system

- Gear type pump (internal geared wheel pump) for loading and steering hydraulics
- Priority valve favoring steering hydraulics
- Lowering brake independent of load
- 3rd section serial
- Loading hydraulic hydraulically pre-activate via ATLAS joystick including float position
- Operating pressure 265 bar  
 Delivery of pump 50.5 l/min

### Loading equipment

- Powerful and solid Z-kinematics with high tear out force
- Hydraulic quick change device
- Activation of all functions via ATLAS joystick
- Parallel movement while using pallet forks
- Automatic shovel return to excavation position
- Locking device acc. to German StVZO for road travel  
 Lifting 5.8 s  
 Lowering 3.5 s  
 Tipping 1.7 s

### Standard equipment

- Rear driving mirrors, foldable
- Heatable rear screen
- Comfortable access to cab from both side
- Single lever operation via ATLAS joystick
- Control lights for speed range, forward/backward travel
- Lights acc. to German StVZO for road travel
- Individually adjustable driver's seat with adjustable right arm rest
- Engine oil heating with heat exchange and 4-stage fan
- Sound absorbing ROPS cab
- Windscreen wipe and wash unit in front and rear
- Sun visor, coat hook, ceiling lamp, stow facility
- Adjustable steering column
- Heat protection glazing with large tinted screens
- Control lights for engine oil pressure, overheating, hydraulic oil temperature, battery power, parking brake, air filter
- Central dashboard with indicators for preheating, engine temperature, fuel, working hour meter

### Options

- 4<sup>th</sup> section front or rear
- Load check valve for lifting and working cylinders
- Slow drive inching pedal
- High speed version 40 km/h
- Extended lifting frame
- Trailer coupling
- Main battery switch
- Corrosion protection for salt
- Special colors and oils
- Cyclone dust separator

- Heatable and air cushioned seats
- Joystick with integrated proportional steering for 3<sup>rd</sup> section (only with ADS)
- Air conditioning, auxiliary heating, comfort cab, canopy cab
- ATLAS diagnostic system (ADS) for monitoring engine parameters with integrated electronic anti-theft device
- Supplementary seat
- Radio
- Warning beacon
- Doors with sliding windows right and left
- Anti-theft device with code stick
- Engine oil preheating 220 V

More options upon request

### Tires

#### Standard:

12.5 - 20 MPT - Multi-purpose tires for sand and gravel surfaces, woodland, roads and paths

#### Special tires:

400/70 R20 XMCL - Wheel loader tires for clay, sand, gravel, fields and greenland, fortified roads  
 405/70 R20 EM - Construction machine tires for clay, sand, gravel, asphaltting, roads, gardening and landscaping

More special tires upon request

### Fuel/oil capacities

Diesel:	100 l
Hydraulic oil:	76 l
Engine oil:	11 l
Front axle:	6 l
Rear axle:	5,8 l
Gear oil:	2,5 l

### Operating data

Shovel capacity acc. to SAE:	0.8 - 1.0 m <sup>3</sup>
Track width:	1510 mm
Turning radius (outer shovel edge):	4164 mm
Tear out force:	5160 daN
Torque:	4100 daN
Tipping load, straight:	3800 kg
Tipping load, articulated:	3362 kg
Lifting capacity at ground level:	4590 daN
Service weight:	4800 kg
Differing data for use of pallet forks (500 mm distance to center of gravity)*	
Static tipping load, straight and articulated:	2640 kg
Lifting capacity:	2845 daN
Payload 80% even surface**:	2112 kg
Payload 60% uneven surface**:	1584 kg

\* Travel with load only permitted close to the ground.

\*\* According to ISO 8313 and EN 474-3.

\*\*\* According to ISO 14396, EU RL97/68/EC.

### Specific gravity for material handling

material	weight (t/m <sup>3</sup> )
concrete	1.9
soil (dry)	1.5
soil (watery)	2.0
rock (fill)	2.4
granite	1.8
limestone	1.6
gravel (dry)	1.9
gravel (watery)	2.1
loam	1.7
plaster	2.2
sand (dry)	1.9
sand (watery)	2.1
sandstone	2.4
shale	2.2
sediment	2.1
crushed stone	1.5
de-icing salt	1.3
clay	1.6
cement	1.7
clinker (stacked)	1.8

### Industry

ember	0.7
brown coal briquette	0.8
ferrous product	7.8
iron ore	2.3
cullet	1.9
gas coke	0.4
timber	0.8
mineral coal	1.2
paper	0.9
slag	1.0
slag concrete	2.7

### Landscaping, agriculture

agricultural crop	0.7
grain	0.6
hay	0.3
potash	1.1
compost	1.0
flour	0.5
clay (watery)	2.3
phosphate fertilizer	2.2
turf (watery)	1.1
turf (dry)	0.4
mineral fertiliser	1.0

## Technical data with standard shovel.

### AR 65 Super

A	5250
B	2652
B <sub>1</sub>	1875
C	3960
C <sub>1</sub>	3165
C <sub>2</sub>	2465
D	80
E	625
F	450
G	2000
H	1870
I	1970
R	1817
R <sub>1</sub>	3715

All specifications in mm

α	40°
---	-----

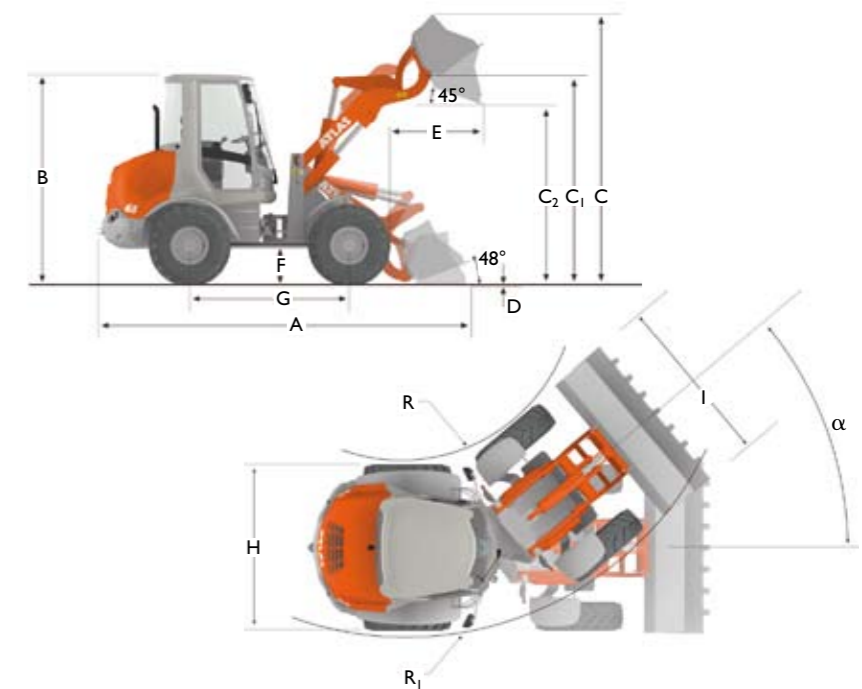

## Technical data with pallet forks.

### AR 65 Super

A	5550
B	2652
B <sub>1</sub>	1875
C	3420
C <sub>1</sub>	297
C <sub>2</sub>	1365
D	60
E	460
E <sub>1</sub>	1195
E <sub>2</sub>	725
F	450
G	2000
H	1870
I	1030
R	1817
R <sub>1</sub>	3715

All specifications in mm

α	40°
---	-----

