

ATLAS Teamwork: ATLAS Teamwork:

AR 35/35 Super



Operation weight 2500 kg / 2875 kg
 Power 24.6 kW (33.5 HP) / 29.4 kW (40 HP)
 Shovel capacity 0.34 m³ / 0.40 m³

AR 40



Operation weight 3300 kg
 Power 29.4 kW (40 HP)
 Shovel capacity 0.50 m³

AR 50



Operation weight 3950 kg
 Power 42 kW (57 HP)
 Shovel capacity 0.70 m³

AR 60



Operation weight 4650 kg
 Power 47.5 kW (65 HP)
 Shovel capacity 0.85 m³

AR 65 Super



Operation weight 4800 kg
 Power 51.3 kW (70 HP)
 Shovel capacity 0.80 - 1.00 m³

AR 75



Operation weight 5600 kg
 Power 55 kW (75 HP)
 Shovel capacity 1.00 m³

AR 75 S



Operation weight 6000 kg
 Power 55 kW (75 HP)
 Shovel capacity 0.80 m³

AR 80



Operation weight 5750 kg
 Power 59.3 kW (81 HP)
 Shovel capacity 1.00 m³

AR 85



Operation weight 6700 kg
 Power 71.2 kW (97 HP)
 Shovel capacity 1.30 m³

AR 95/95 Super



Operation weight 7900 kg / 8100 kg
 Power 74.9 kW (102 HP) / 92 kW (125 HP)
 Shovel capacity 1.40 - 1.60 m³

Technical data without engagement.
 Subject to change without notice.



ATLAS WEYHAUSEN GmbH
 Maschinenfabrik
 Visbeker Straße 35
 D-27793 Wildeshausen
 Telephone +49 (0)44 31/981-0
 Fax +49 (0)44 31/981-225
 www.radlader.com

01/2010

AR 35 Super



- Landscaping, agricultural sector, narrow construction sites
- Operating weight: 2875 kg
- Power: 29.4 kW



TECHNICAL DATA AR 35 Super

Engine

Make: Perkins Diesel engine 403D-15T
 Type: water cooled
 Power^{***}: set to 29.4 kW (40 hp)
 at 2800 min⁻¹
 Max. torque: 112 Nm at 1800 min⁻¹
 Stroke: 1496 cm³
 Cylinders: 3 in line
 Electrical System: Operating voltage 12 V
 Battery 12 V/66 Ah
 Alternator 14 V/65 A
 Starter 12 V/2,0 kW

Drive

- Output-regulated hydrostatic drive with pressure cut off and closed circuit acting on all 4 wheels
- Speed with standard tires:
 Operating speed range 0–6,5 km/h
 Road speed range 0–20 km/h
- 1st and 2nd hydraulic gear can be engaged under load, forward/backward travel also
- Forward/backward travel, speed ranges and off-position operational via ATLAS joystick
- Drive operated by accelerator and separate inching pedal for best distribution of the hydraulic power for thrust and lifting forces

Axles

Rigid axles with planetary reduction gears in wheel hubs. 45% - differential lock in front axle.

Brakes

Standard brake: Drum brake on front axle via cardan acting on all 4 wheels. Supplementary brake functions via inching pedal and hydrostatic drive acting on all 4 wheels.

Parking brake: Drum brake via funicular link acting on all 4 wheels with engine switch off.

Steering

- Fully hydraulic center pivot steering
- Front and rear wheels follow the same track
- Steering angle of 40° to each side, ±12° angular movement at rear of vehicle
- Operating pressure of steering hydraulics 145 bar
- Emergency steering function

Hydraulic system

- Gear pump for loading and steering hydraulics
- Priority valve favoring steering hydraulics
- 3rd steering section for loading hydraulics mechanically controlled by ATLAS joystick, including float position
- Operating pressure 230 bar
 Delivery of pump 39 l/min

Loading equipment

- Powerful and solid Z- kinematics with high tear out force
- Hydraulic quick change device
- Activation of all functions by ATLAS joystick
- Automatic mid position of joystick
- Parallel movement while using pallet forks
- Automatic shovel return to excavation position
- Locking device acc. to German StVZO for road travel

Lifting	4 s
Lowering	3,5 s
Tipping	1 s

Standard equipment

- ATLAS canopy cabin with roll-bar protection
- Activation of all functions by ATLAS joystick
- Control lights for speed range, forward/backward travel
- Lights acc. to German StVZO for road travel
- Individually adjustable driver's seat
- Control lights for engine oil pressure, overheating, hydraulic oil temperature, battery power, parking brake, air filter
- Central dashboard with indicators for preheating, fuel, working hour meter

Options

- 4th section front or rear
- Main battery switch
- Special paintings and oils
- Cyclone dust separator
- Trailer coupling
- Left hinged adjustable window, right window to open can be fastened
- Hot water heating with heat exchange and 3-stage-fan
- Front windscreen ventilation, variable output
- Rear driving mirrors, foldable
- Sound absorbing ROPS cab
- Windscreen wipe and wash unit in front and rear
- Sun visor, ceiling lamp, stow facility
- Heat protection glazing with large tinted screens
- Working lights front and rear
- Anti-theft-device with code stick
- Radio
- Warning beacon

More options upon request

Tires

Standard:
 10.0/75 – 15.3 MPT – Multi-purpose tires for sand and gravel surface, woodland, roads and paths

Special tires:
 11.5/80 – 15.3 MPT – Multi-purpose tires for sand and gravel surface, woodland, roads and paths
 12 – 16.5 MT – Construction machine tires for soft surfaces, asphalt, roads, gardening and landscaping
 31 X 15.5 – 15E – Multi-purpose tires for earth moving machines, particularly surface friendly
 15.5/55 R18 – Multi-purpose tires for earth moving machines, particularly surface friendly, gardening and landscaping

More special tires upon request

Fuel/oil capacities

Diesel:	58 l
Hydraulic oil:	28 l
Engine oil:	3 l
Front axle:	4 l
Rear axle:	3,5 l
Gear oil:	0,65 l
Cooling liquid:	6 l

Operating data

Shovel capacity acc. to SAE:	0,4 m ³
Track width:	1070 mm
Turning radius	
(outer shovel edge):	3242 mm
Tear out force:	2430 daN
Torque:	2300 daN
Tipping load, straight:	1911 kg
Tipping load, articulated:	1700 kg
Lifting capacity at ground level:	2100 daN
Service weight:	2875 kg

Differing data for use of pallet forks (500 mm distance to center of gravity)*
 Static tipping load, articulated: 1422 kg
 Lifting capacity: 1600 daN
 Payload 80% even surface^{**}: 1138 kg
 Payload 60% uneven surface^{**}: 853 kg

* Travel with load only permitted close to the ground.

** According to ISO 8313 and EN 474-3

*** According to ISO 14396, EU RL97/68/EC.

Specific gravity for material handling

material	weight (t/m ³)
concrete	1,9
soil (dry)	1,5
soil (watery)	2,0
rock (fill)	2,4
granite	1,8
limestone	1,6
gravel (dry)	1,9
gravel (watery)	2,1
loam	1,7
plaster	2,2
sand (dry)	1,9
sand (watery)	2,1
sandstone	2,4
shale	2,2
sediment	2,1
crushed stone	1,5
de-icing salt	1,3
clay	1,6
cement	1,7
clinker (stacked)	1,8

Industry

ember	0,7
brown coal briquette	0,8
ferrous product	7,8
iron ore	2,3
cullet	1,9
gas coke	0,4
timber	0,8
mineral coal	1,2
paper	0,9
slag	1,0
slag concrete	2,7

Landscaping, agriculture

agricultural crop	0,7
grain	0,6
hay	0,3
potash	1,1
compost	1,0
flour	0,5
clay (watery)	2,3
phosphate fertilizer	2,2
turf (watery)	1,1
turf (dry)	0,4
mineral fertiliser	1,0

Technical data with standard shovel.

AR 35 Super

A	4240
B ₁	1605
B ₂	2340
B ₃	2270
C	3340
C ₁	2800
C ₂	2300
D	55
E	595
F	350
G	1580
H	1350
I	1350
R	1495
R ₁	2872

All specifications in mm

α	40°
---	-----

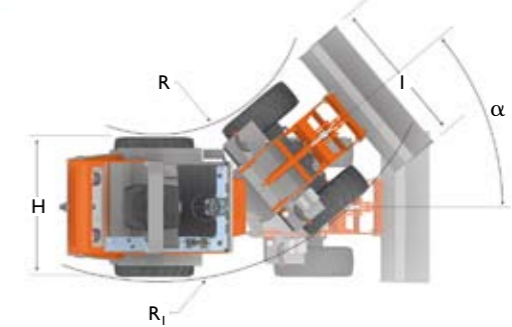
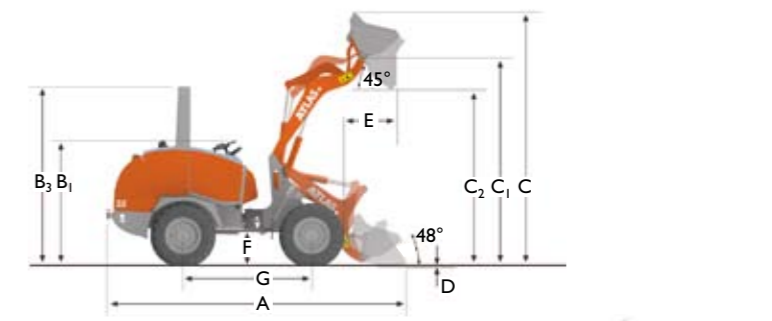

Differing data ROPS-cabin



Technical data with pallet forks.

AR 35 Super

A	4730
B ₁	1605
B ₂	2340
B ₃	2270
C	3010
C ₁	2550
C ₂	1130
D	145
E	300
E ₁	1010
E ₂	680
F	350
G	1580
H	1350
I	1030
R	1495
R ₁	2872

All specifications in mm

α	40°
---	-----

